

FREEHUB BODY CONVERSION INSTRUCTIONS: 2004 AND LATER ROLF PRIMA REAR WHEELS

Conversion kit contents:

- 1 Shimano® or Campagnolo® compatible cassette body
- 1 Axle and axle end cap for use with Shimano® or Campagnolo® cassette body.

! CAUTION !

The following hub conversion information is provided as a guide for the professional mechanic. These instructions are written with the assumption that the mechanic is familiar with bicycle repair principles and has suitable and appropriate tools.

[Refer to exploded assembly view below]

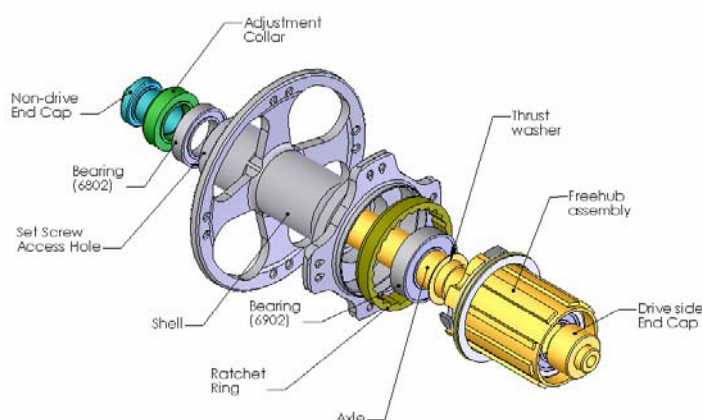

1. Loosen the three set screws [4 set screws in tandem hubs] on the adjustable side of the hub by inserting a 2mm Allen wrench in the access hole in the left side of the hub shell.
2. Remove the axle end cap from the adjustable side of the hub. A small amount of corrosion is not unusual and may make it difficult to remove axle end caps by hand. If needed, thread a M6 bolt into the axle end and pull on the bolt for a better grip. The end cap may need to be driven out with a drift. Insert a drift into the axle from the nonadjustable side [old QR skewers work well] and tap on the end of the bolt to remove the axle end cap.
3. Working over a workbench or table, remove the axle and free hub body by pulling the free hub body away from the hub. Orient the wheel free hub side up and watch carefully for pawls and pawl springs, which may fall out.
4. A small amount of corrosion is not unusual, which may require the axle to be driven out. With the wheel oriented free hub side down, use a suitable drift or socket with outside diameter close to the outside diameter of the axle and gently drive the axle a short distance. By moving the axle only a short distance, the corrosion bond will be broken and it should be possible to remove the axle and free hub body by hand, as outlined above.



INSTRUCTIONS FOR FREEHUB BODY CONVERSION 2004+ ROLF PRIMA REAR WHEELS [cont.]

5. Locate the thrust washer, which sits between the free hub body inboard bearing and the free hub-side bearing in the hub shell. This washer will often adhere to one of the bearings, held in place by a film of grease. Clean the washer and set it aside for reassembly.
6. To reassemble, be sure the drive side axle end cap is securely installed on the axle. This part is bonded in place and should not be loose. It may be removed for replacement if damaged. The drive side axle end cap must be bonded with Loctite™ RC-680 retaining compound.
7. Apply a thin film of oil on the replacement axle and install the replacement free hub body on the axle, with the outboard free hub body bearing contacting the non-drive side axle end cap.
8. Place the thrust washer on the axle, against the inboard free hub bearing.
9. Insert the axle and free hub body assembly into the hub shell from the drive side. Rotate the free hub body counterclockwise to engage the pawls and ratchet ring.
10. Place the adjusting collar on the non-drive side of the axle and insert the non-drive side axle end cap into the axle end.
11. Before setting the bearing adjustment it is important to ensure the adjustment collar is fully seated against the hub bearing, thus removing any play.
12. Tighten the set screws firmly with a 2mm Allen wrench to set the bearing adjustment. Do not over tighten the set screws. Damage to the adjustment collar will result. Properly tightened, the set screws will securely retain the axle end cap.
13. Once the free hub has been converted the wheel will need to be re-dished for Shimano or Campagnolo.